

LM-80 TEST REPORT



The following tested product(s) were submitted and identified by the vendor as:

Applicant : EVERLIGHT ELECTRONICS CO., LTD

Address of Applicant : No. 6-8, Zhonghua Rd., Shulin Dist., New Taipei City 23860, Taiwan

Testing Laboratory : Reliability Lab, Everlight Electronics

Testing Address : No.25, Lane 76, Sec. 3, Chung Yang Road, Tucheng, New Taipei City 23673, Taiwan

Product Name : Low-Mid Power LED

Model/ Serial Number : 67-21S Series (3000K)

Manufacturer : Everlight Electronics Co., LTD

Rating : DC 60 mA

Test Standard/Method : IES LM-80-08 Approved Method: Measuring Lumen Maintenance of LED Light Sources

Revision : 4

The submitted products have been tested as requested and the following results were obtained, and the report, not applicable for lawsuit, refers only to the unit(s) submitted for test.

Signed for and on behalf of
EVERLIGHT Ltd.

Luca Tai

1 DATE OF RECEIPT OF SAMPLES

Apr. 22, 2014

2 DATE(S) OF PERFORMANCE OF THE TEST

Apr. 24, 2014 ~Feb. 26, 2015

3 IDENTITY OF SAMPLES

Quantity	Model	Serial Number
25	67-21S Series	# A01- # A25(55 °C)
25	67-21S Series	# B01- # B25(85 °C)
25	67-21S Series	# C01- # C25(105 °C)

4 TEST ITEMS**4.1 Date Summary of Lumen and Color Maintenance**

Test results were concluded by different Temperatures (Ts)

4.2 Lumen Maintenance and Color Maintenance Test

Testing specifications by different case temperatures according to IES LM-80-08 approved.

Method: Measuring Lumen Maintenance of LED Light Sources and client's requirements were implemented per the following items.

4.2.1 Total Luminous Flux(Φ_v)

The test results of total luminous flux were implemented referring to Clause 2 PROPERTIES OF LEDS & Clause 6 MEASUREMENT OF LUMINOUS FLUX of CIE127:2007 2nd edition MRASUREMENT OF LEDS and IES LM-80-08 Approved Method: Measuring Lumen Maintenance of LED Light Sources, when the UUTs were powered with constant current of If.

4.2.2 Correlated Color Temperature (CCT), CIE Color Coordinate (CIE_x, CIE_y) & Chromaticity shift($\Delta u'$, $\Delta v'$)

The test results of correlated color temperature were implemented referring to CIE 127:2007 2nd editions MRASUREMENT OF LEDS, CIE 15:2004 COLORIMETY.

The test results of color coordinate were implemented referring to CIE 127:2007 2nd edition MRASUREMENT OF LEDS, CIE 15:2004 COLORIMETRY

5 TESTING LABORATORY IS ACCREDITED BY

5.1 ISO 17025 accredited in respect of laboratory is approved by TAF Certificate No. :
L2773-130705

5.2 EPA-Recognized Laboratories No.: 1125371

6 TEST CONDITIONS

6.1 Main Test Equipment:

Name	Brand	Model	Traceability	Calibration Date	Due Date
Spectroradiometer	Photal	LE-5400	NVLAP (200951-0)	2013/5/31	2016/5/31
Integrating Sphere	Labsphere	LMS-100CM			
Standard Light Source	Labsphere	SCL-1400			
Source Meter	Keithley	2612A	Chroma (TAF 0245)	2014/9/11	2015/9/11
Source Meter	Agilent	N5751A	宇正 (TAF 0742)	2015/2/25	2016/2/25
Digital Multimeter	Agilent	E3634A	ETC (TAF 0025)	2014/5/10	2015/5/10

6.2 Environmental Conditions:

Temperature: (25 ± 1) °C

Relative Humidity: < 65 %RH

6.3 Measurement Conditions:

Interval Time: 1000 h

Warm up Time: < 1 minute (initial)

Relative measurement uncertainty: 1.1 % (95 % Confidence Level)

6.4 UUT Conditions:

Drive Current: DC 60mA

Forward Voltage: 3V

Power Consumption: 0.2W (Rated Value)

Lumen: 20 lm – 33 lm

CCT: 3000K

Package Dimension: L 3.5 mm x W 2.8 mm

Prior operation: 0 h

Total Operation Duration: 6000 h

6.5 Photograph of device

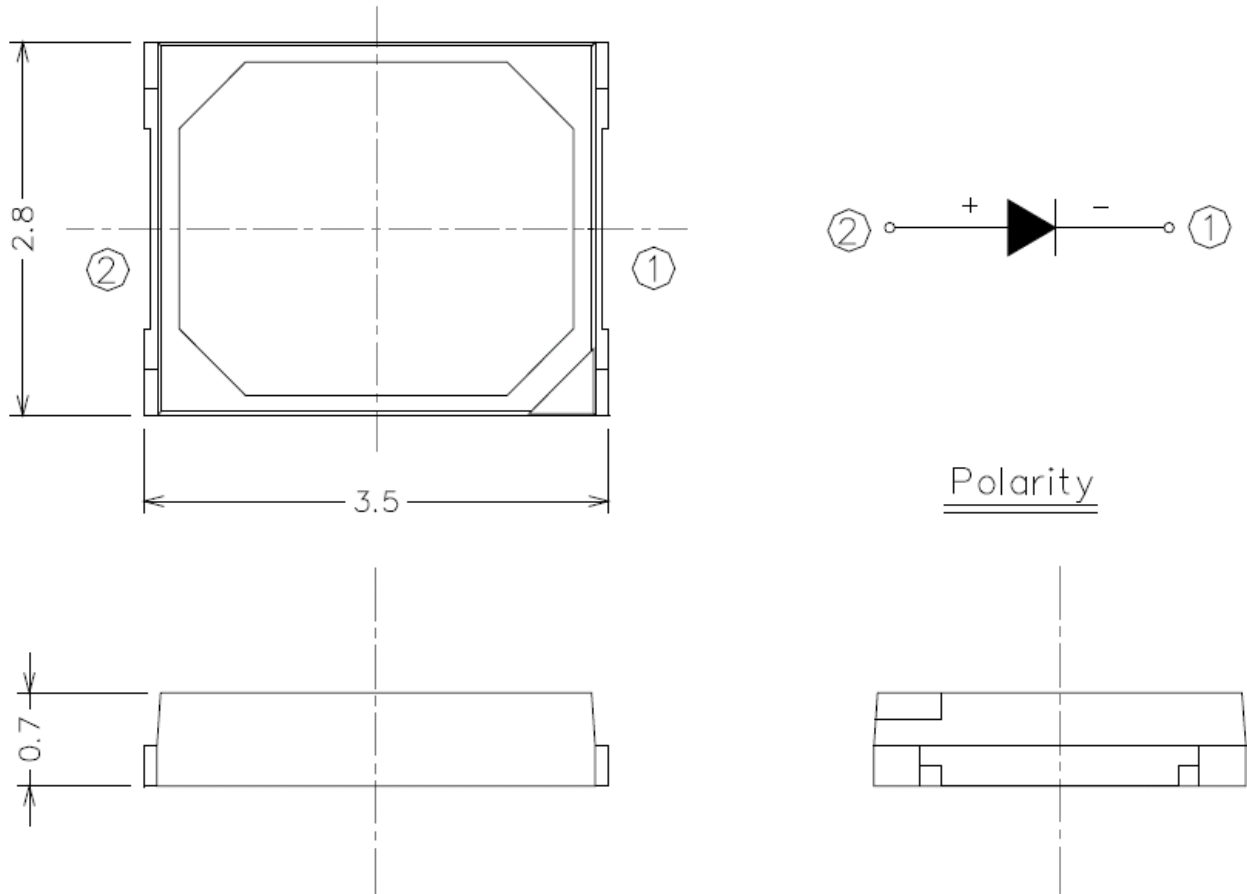

7 TEST SUMMARY:

7.1 Data Summary of Lumen and Color Maintenance

Temp.	Initial(0 h)		Luminous Maintenance (%)						
	TLF(lm)	Vf(V)	0 h	1000 h	2000 h	3000 h	4000 h	5000 h	6000 h
55 °C	21.8	3.0	100%	102.50%	102.14%	101.49%	100.35%	100.00%	100.01%
85 °C	21.7	3.0	100%	101.42%	100.59%	99.62%	98.70%	97.38%	96.96%
105 °C	21.8	3.0	100%	100.66%	99.90%	99.02%	97.21%	96.53%	96.26%

Temp.	Initial(0 h)			Chromaticity Shift ($\Delta u'v'$)					
	CIE u'	CIE v'	CCT	1000 h	2000 h	3000 h	4000 h	5000 h	6000 h
55 °C	0.2476	0.5217	3075	0.00047	0.00043	0.00107	0.00107	0.00107	0.00107
85 °C	0.2474	0.5211	3086	0.00035	0.00111	0.00166	0.00218	0.00231	0.00270
105 °C	0.2475	0.5214	3081	0.00035	0.00128	0.00279	0.00299	0.00355	0.00436

7.2 Chart of lumen maintenance and TM-21 projection

7.2.1 Chart of lumen maintenance

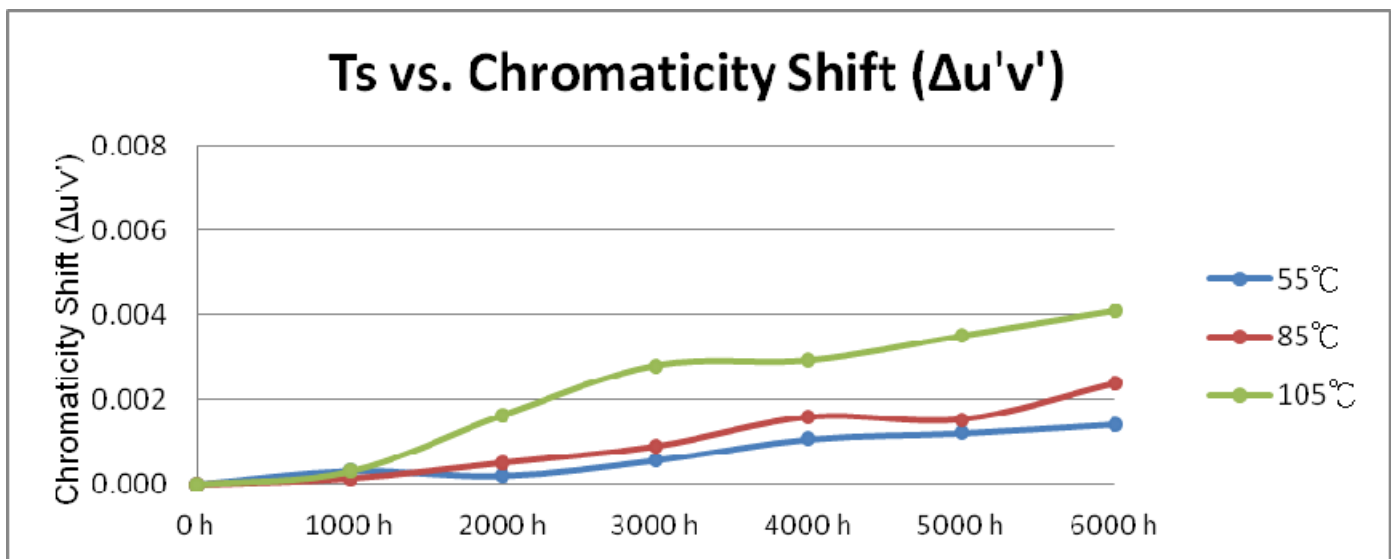
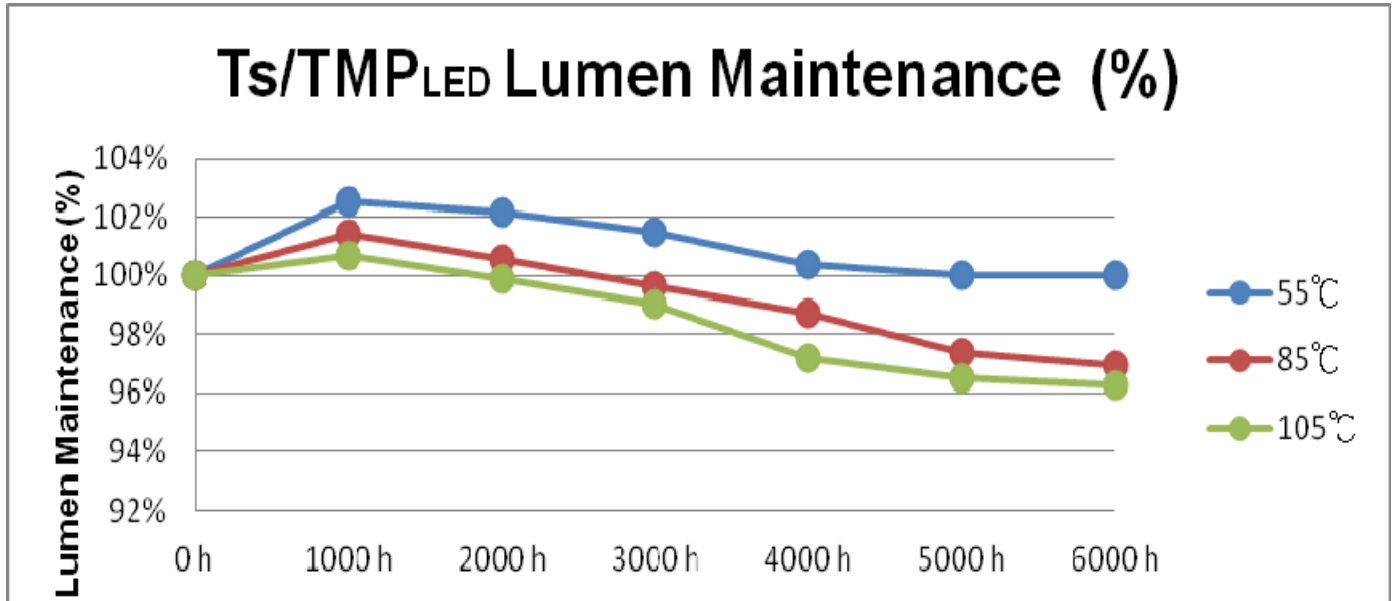

7.2.2 LM-80 test and TM-21 Projection

Table : Report at each LM-80 Test Condition

Case Temperature 1		Case Temperature 2		Case Temperature 3	
Temperature (°C):	55	Temperature (°C):	85	Temperature (°C):	105
Temperature (°K):	328.15	Temperature (°K):	358.15	Temperature (°K):	378.15
α :	5.65E-06	α :	9.47E-06	α :	9.85E-06
B:	1.03	B:	1.02	B:	1.02
Calculated L70 (hrs):	69000	Calculated L70 (hrs):	40000	Calculated L70 (hrs):	38000
Reported L70 (hrs):	>36000	Reported L70 (hrs):	>36000	Reported L70 (hrs):	>36000

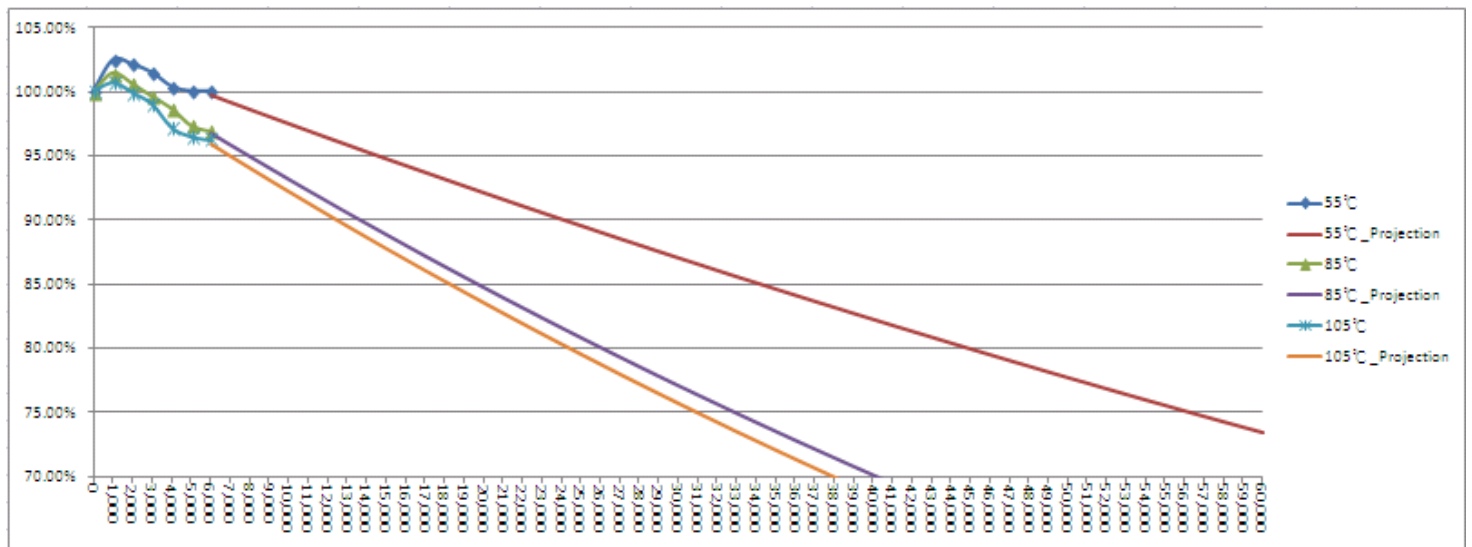

7.3 Lumen Maintenance and Color Maintenance Test

7.3.1 Test Condition: Ts = 55 °C

Requirement	
Case Temperature [Ts]: 53.9 °C	Average [Ts]: 53.9 °C
Ambient Temperature [Ta]: 52.1 °C	Average [Ta]: 52.1 °C
Driver Current: 60 mA	Air Flow: Minimized
Measurement Current: 60 mA	Relative Humidity: < 65 %RH

7.3.1.1 Total Luminous Flux (Φ_v)

S/N	Initial(0 h)		Luminous Maintenance(Φ_v)					
	TLF(lm)	Vf(V)	1000 h	2000 h	3000 h	4000 h	5000 h	6000 h
A01	22.2	3.0	102.36%	101.64%	101.12%	100.03%	100.25%	99.77%
A02	21.1	3.0	102.82%	102.73%	101.87%	100.83%	100.84%	100.66%
A03	22.2	3.0	101.41%	101.11%	100.45%	99.30%	98.73%	98.48%
A04	21.9	3.0	102.11%	101.88%	100.41%	99.58%	99.10%	98.38%
A05	21.2	3.0	102.98%	102.64%	102.09%	101.10%	101.48%	101.27%
A06	21.6	3.0	103.02%	103.09%	102.72%	101.64%	101.76%	101.81%
A07	21.3	3.0	102.34%	102.55%	102.06%	100.63%	100.71%	100.90%
A08	21.0	3.0	103.30%	103.35%	102.94%	101.98%	101.07%	101.41%
A09	21.4	3.0	102.37%	102.30%	101.94%	100.96%	101.15%	101.07%
A10	21.8	3.0	102.39%	101.80%	101.02%	100.21%	99.94%	99.73%
A11	22.3	3.0	101.74%	101.29%	100.72%	99.60%	98.12%	99.13%
A12	21.8	3.0	102.16%	101.79%	100.94%	99.72%	98.44%	99.19%
A13	21.6	3.0	103.65%	102.91%	101.94%	100.07%	100.88%	100.73%
A14	22.1	3.0	103.29%	103.19%	102.49%	101.55%	101.25%	101.03%
A15	21.1	3.0	102.92%	102.64%	102.59%	101.71%	100.67%	101.38%
A16	22.1	3.0	102.03%	101.57%	100.86%	100.14%	99.47%	99.31%
A17	21.8	3.0	102.58%	101.93%	101.03%	99.68%	99.63%	99.54%
A18	22.0	3.0	103.17%	102.71%	101.98%	100.42%	99.64%	99.23%
A19	22.3	3.0	102.28%	101.71%	100.98%	100.15%	98.71%	98.96%
A20	22.6	3.0	101.63%	101.23%	100.88%	100.17%	99.81%	99.60%
A21	21.7	3.0	101.93%	101.36%	100.64%	99.74%	98.93%	98.98%
A22	22.5	3.0	101.80%	101.46%	100.73%	99.30%	98.68%	99.11%
A23	21.8	3.0	103.58%	103.01%	102.30%	101.23%	100.63%	100.50%
A24	21.9	3.0	102.07%	100.82%	100.31%	98.21%	98.82%	98.92%
A25	21.3	3.0	102.66%	102.75%	102.30%	100.90%	101.34%	101.22%
Avg.	21.8	3.0	102.50%	102.14%	101.49%	100.35%	100.00%	100.01%
Min.	21.0	3.0	101.41%	100.82%	100.31%	98.21%	98.12%	98.38%
Max.	22.6	3.0	103.65%	103.35%	102.94%	101.98%	101.76%	101.81%
Med.	21.8	3.0	102.37%	101.93%	101.12%	100.17%	99.94%	99.73%
St. Dev.	0.4587	0.0056	0.0062	0.0074	0.0082	0.0090	0.0110	0.0105

7.3.1.2 CCT, CIE_x, CIE_y & Chromaticity Shift($\Delta u'v'$)

S/N	Initial(0 h)			Chromaticity Shift($\Delta u'v'$)					
	CIE _x	CIE _y	CCT	1000 h	2000 h	3000 h	4000 h	5000 h	6000 h
A01	0.4336	0.4055	3073	0.00022	0.00022	0.00108	0.00170	0.00156	0.00184
A02	0.4343	0.4072	3074	0.00036	0.00014	0.00064	0.00113	0.00120	0.00141
A03	0.4323	0.4043	3085	0.00051	0.00067	0.00149	0.00205	0.00233	0.00248
A04	0.4356	0.4086	3063	0.00073	0.00081	0.00170	0.00213	0.00234	0.00291
A05	0.4329	0.4067	3095	0.00036	0.00032	0.00085	0.00141	0.00127	0.00141
A06	0.4314	0.4064	3118	0.00045	0.00014	0.00051	0.00100	0.00103	0.00120
A07	0.4303	0.4033	3111	0.00028	0.00014	0.00072	0.00135	0.00130	0.00142
A08	0.4322	0.4064	3103	0.00040	0.00030	0.00045	0.00078	0.00108	0.00120
A09	0.4299	0.4045	3129	0.00036	0.00040	0.00078	0.00127	0.00141	0.00163
A10	0.4361	0.4076	3046	0.00054	0.00060	0.00128	0.00164	0.00198	0.00214
A11	0.4383	0.4079	3012	0.00050	0.00073	0.00135	0.00184	0.00215	0.00226
A12	0.4355	0.4062	3044	0.00071	0.00073	0.00156	0.00191	0.00233	0.00269
A13	0.4302	0.4012	3096	0.00061	0.00020	0.00089	0.00163	0.00184	0.00191
A14	0.4349	0.405	3045	0.00050	0.00041	0.00114	0.00106	0.00135	0.00135
A15	0.4333	0.4058	3080	0.00071	0.00060	0.00122	0.00164	0.00179	0.00198
A16	0.4339	0.4058	3070	0.00051	0.00063	0.00156	0.00170	0.00240	0.00262
A17	0.4341	0.4078	3081	0.00050	0.00051	0.00114	0.00164	0.00213	0.00206
A18	0.4334	0.4053	3073	0.00054	0.00020	0.00072	0.00128	0.00166	0.00192
A19	0.4385	0.4081	3009	0.00061	0.00063	0.00135	0.00178	0.00177	0.00214
A20	0.4348	0.4068	3062	0.00041	0.00054	0.00120	0.00156	0.00184	0.00198
A21	0.4317	0.405	3101	0.00020	0.00051	0.00135	0.00184	0.00227	0.00241
A22	0.4384	0.4088	3017	0.00040	0.00051	0.00120	0.00177	0.00208	0.00242
A23	0.4305	0.4039	3114	0.00051	0.00030	0.00072	0.00120	0.00142	0.00184
A24	0.4326	0.4066	3099	0.00041	0.00041	0.00135	0.00212	0.00219	0.00233
A25	0.4342	0.4075	3078	0.00032	0.00020	0.00057	0.00106	0.00120	0.00141
Avg.	0.433716	40.61%	3075	0.00047	0.00043	0.00107	0.00107	0.00107	0.00107
Min.	0.4299	40.12%	3009	0.00020	0.00014	0.00045	0.00078	0.00103	0.00120
Max.	0.4385	40.88%	3129	0.00071	0.00073	0.00156	0.00212	0.00240	0.00269
Med.	0.43365	40.63%	3079	0.00050	0.00046	0.00117	0.00163	0.00181	0.00198
St. Dev.	0.0027	0.0018	36.06	0.00013	0.00019	0.00035	0.00036	0.00043	0.00045

7.3.2 Test Condition: $T_s = 85\text{ }^\circ\text{C}$

Requirement	
Case Temperature [Ts]: 84.6 °C	Average [Ts]: 84.7 °C
Ambient Temperature [Ta]: 81.2 °C	Average [Ta]: 81.2 °C
Driver Current: 60 mA	Air Flow: Minimized
Measurement Current: 60 mA	Relative Humidity: < 65 %RH

 7.3.2.1 Total Luminous Flux (Φ_v)

S/N	Initial(0 h)		Luminous Maintenance(Φ_v)					
	TLF(lm)	Vf(V)	1000 h	2000 h	3000 h	4000 h	5000 h	6000 h
B01	21.3	3.0	101.56%	100.58%	99.03%	98.09%	97.36%	96.64%
B02	21.1	3.0	101.94%	101.27%	100.49%	99.55%	98.82%	98.36%
B03	21.8	3.0	101.08%	100.75%	97.94%	97.02%	95.63%	94.99%
B04	21.7	3.0	101.77%	102.40%	98.82%	97.90%	96.09%	95.37%
B05	22.3	3.0	101.20%	100.44%	100.43%	99.53%	98.08%	97.71%
B06	21.4	3.0	102.64%	101.67%	100.50%	99.57%	98.49%	98.32%
B07	22.1	3.0	100.83%	101.93%	99.63%	98.73%	95.69%	95.94%
B08	22.3	3.0	100.37%	98.76%	98.49%	97.59%	96.79%	96.32%
B09	21.4	3.0	101.39%	100.45%	99.10%	98.17%	95.79%	95.15%
B10	22.5	3.0	101.02%	100.13%	99.83%	98.94%	97.42%	97.25%
B11	22.0	3.0	101.55%	101.86%	100.76%	99.86%	98.14%	97.67%
B12	21.6	3.0	101.48%	101.68%	101.23%	100.30%	99.80%	99.64%
B13	21.1	3.0	102.06%	99.09%	98.70%	97.75%	96.73%	96.79%
B14	22.3	3.0	100.98%	100.40%	98.44%	97.54%	95.99%	95.26%
B15	21.6	3.0	101.63%	100.95%	101.40%	100.47%	99.44%	99.51%
B16	21.3	3.0	101.71%	99.26%	99.43%	98.49%	97.72%	96.91%
B17	22.1	3.0	100.74%	100.12%	97.48%	96.58%	95.20%	94.62%
B18	21.5	3.0	101.86%	100.90%	100.88%	99.95%	99.24%	99.29%
B19	21.2	3.0	101.71%	99.20%	99.47%	98.53%	97.42%	96.68%
B20	21.4	3.0	101.82%	101.13%	99.17%	98.23%	97.89%	97.11%
B21	21.5	3.0	101.63%	101.61%	101.41%	100.48%	98.96%	98.57%
B22	21.0	3.0	101.94%	100.00%	99.65%	98.69%	96.97%	96.49%
B23	21.1	3.0	101.18%	99.50%	99.71%	98.76%	97.73%	97.15%
B24	22.2	3.0	100.66%	100.87%	99.68%	98.78%	96.76%	96.14%
B25	22.4	3.0	100.78%	99.68%	98.86%	97.96%	96.36%	96.16%
Avg.	21.7	3.0	101.42%	100.59%	99.62%	98.70%	97.38%	96.96%
Min.	21.0	3.0	100.37%	98.76%	97.48%	96.58%	95.20%	94.62%
Max.	22.5	3.0	102.64%	102.40%	101.41%	100.48%	99.80%	99.64%
Med.	21.6	3.0	101.51%	100.60%	99.64%	98.71%	97.42%	96.85%
St. Dev.	0.4745	0.0065	0.0054	0.0101	0.0108	0.0107	0.0132	0.0144

7.3.2.2 CCT, CIE_x, CIE_y & Chromaticity Shift($\Delta u'v'$)

S/N	Initial(0 h)			Chromaticity Shift($\Delta u'v'$)					
	CIE _x	CIE _y	CCT	1000 h	2000 h	3000 h	4000 h	5000 h	6000 h
B01	0.42870	0.40030	3117	0.00063	0.00117	0.00172	0.00258	0.00239	0.00287
B02	0.43060	0.40480	3119	0.00032	0.00022	0.00054	0.00103	0.00112	0.00148
B03	0.43510	0.40730	3061	0.00122	0.00175	0.00244	0.00300	0.00311	0.00350
B04	0.43390	0.40300	3046	0.00086	0.00134	0.00228	0.00272	0.00302	0.00350
B05	0.43580	0.40790	3054	0.00117	0.00166	0.00239	0.00322	0.00316	0.00350
B06	0.43860	0.40940	3019	0.00100	0.00161	0.00236	0.00278	0.00302	0.00350
B07	0.43120	0.40380	3100	0.00103	0.00170	0.00244	0.00288	0.00319	0.00354
B08	0.43280	0.40450	3079	0.00040	0.00082	0.00125	0.00166	0.00170	0.00197
B09	0.43160	0.40420	3096	0.00142	0.00208	0.00297	0.00410	0.00405	0.00428
B10	0.43320	0.40640	3087	0.00117	0.00186	0.00256	0.00306	0.00328	0.00366
B11	0.43590	0.40590	3036	0.00094	0.00139	0.00192	0.00208	0.00222	0.00242
B12	0.43100	0.40450	3110	0.00022	0.00030	0.00078	0.00114	0.00156	0.00194
B13	0.43150	0.40490	3105	0.00067	0.00112	0.00184	0.00284	0.00270	0.00294
B14	0.43070	0.40250	3099	0.00028	0.00045	0.00063	0.00098	0.00108	0.00149
B15	0.43300	0.40660	3091	0.00010	0.00036	0.00085	0.00113	0.00149	0.00186
B16	0.43240	0.40690	3104	0.00022	0.00050	0.00106	0.00177	0.00178	0.00208
B17	0.43260	0.40500	3087	0.00045	0.00103	0.00156	0.00184	0.00205	0.00236
B18	0.43480	0.40730	3067	0.00020	0.00050	0.00076	0.00112	0.00130	0.00184
B19	0.43720	0.40900	3039	0.00153	0.00197	0.00236	0.00278	0.00290	0.00330
B20	0.43120	0.40640	3121	0.00014	0.00051	0.00089	0.00158	0.00153	0.00237
B21	0.43150	0.40350	3092	0.00078	0.00142	0.00219	0.00269	0.00278	0.00356
B22	0.43510	0.40610	3052	0.00128	0.00166	0.00186	0.00214	0.00233	0.00269
B23	0.43470	0.40520	3050	0.00086	0.00158	0.00228	0.00308	0.00322	0.00369
B24	0.43060	0.40490	3120	0.00010	0.00030	0.00072	0.00108	0.00130	0.00152
B25	0.43390	0.40730	3081	0.00028	0.00054	0.00089	0.00117	0.00135	0.00170
Avg.	0.43310	0.40550	3081	0.00069	0.00111	0.00166	0.00218	0.00231	0.00270
Min.	0.42870	0.40030	3019	0.00010	0.00022	0.00054	0.00098	0.00108	0.00148
Max.	0.43860	0.40940	3121	0.00153	0.00208	0.00297	0.00410	0.00405	0.00428
Med.	0.43280	0.40520	3087	0.00067	0.00117	0.00184	0.00214	0.00233	0.00269
St. Dev.	0.0024	0.0021	29.58	0.00045	0.00061	0.00075	0.00088	0.00085	0.00085

7.3.3 Test Condition: Ts = 105 °C

Requirement	
Case Temperature [Ts]: 104.1 °C	Average [Ts]: 104.4 °C
Ambient Temperature [Ta]: 101.0 °C	Average [Ta]: 101.0 °C
Driver Current: 60 mA	Air Flow: Minimized
Measurement Current: 60 mA	Relative Humidity: < 65 %RH

7.3.3.1 Total Luminous Flux (Φ_v)

S/N	Initial(0 h)		Luminous Maintenance(Φ_v)					
	TLF(lm)	Vf(V)	1000 h	2000 h	3000 h	4000 h	5000 h	6000 h
C01	22.0	3.0	101.16%	100.37%	99.36%	96.81%	97.07%	96.33%
C02	21.1	3.0	102.83%	102.29%	101.73%	99.67%	99.69%	98.89%
C03	21.2	3.0	99.64%	98.50%	97.35%	95.06%	94.76%	94.53%
C04	21.9	3.0	99.97%	99.12%	97.94%	96.15%	95.47%	94.75%
C05	21.8	3.0	99.60%	98.52%	97.07%	94.42%	94.13%	93.48%
C06	22.2	3.0	99.92%	98.91%	97.66%	95.76%	95.15%	94.78%
C07	22.0	3.0	99.44%	98.31%	97.25%	95.59%	94.93%	94.50%
C08	22.1	3.0	101.80%	101.35%	100.75%	99.51%	99.17%	99.03%
C09	22.3	3.0	98.87%	97.69%	96.17%	93.33%	93.04%	92.64%
C10	21.7	3.0	99.22%	97.46%	96.10%	94.35%	93.65%	93.13%
C11	22.1	3.0	100.03%	99.09%	98.28%	97.13%	96.68%	96.61%
C12	21.3	3.0	102.41%	101.80%	100.86%	99.37%	98.22%	97.56%
C13	21.8	3.0	100.89%	99.65%	98.31%	94.93%	95.15%	94.67%
C14	21.2	3.0	102.23%	102.35%	102.07%	100.99%	100.53%	100.42%
C15	21.7	3.0	101.61%	101.15%	100.35%	99.01%	97.87%	97.60%
C16	21.5	3.0	101.10%	100.49%	99.67%	97.27%	97.15%	96.80%
C17	22.0	3.0	101.06%	99.89%	98.83%	97.29%	96.50%	96.11%
C18	21.4	3.0	101.87%	101.84%	101.53%	100.10%	99.08%	98.87%
C19	22.1	3.0	99.20%	98.28%	97.33%	95.88%	94.69%	94.69%
C20	21.3	3.0	101.94%	101.39%	100.80%	98.79%	97.07%	97.60%
C21	22.2	3.0	100.02%	98.99%	97.91%	96.37%	94.56%	94.78%
C22	22.3	3.0	99.09%	98.66%	98.61%	97.47%	96.13%	96.41%
C23	22.2	3.0	99.97%	99.02%	97.87%	96.31%	95.14%	94.82%
C24	21.0	3.0	101.86%	101.44%	100.98%	99.24%	98.95%	98.75%
C25	22.0	3.0	100.87%	100.90%	100.68%	99.57%	98.57%	98.75%
Avg.	21.8	3.0	100.66%	99.90%	99.02%	97.21%	96.53%	96.26%
Min.	21.0	3.0	98.87%	97.46%	96.10%	93.33%	93.04%	92.64%
Max.	22.3	3.0	102.83%	102.35%	102.07%	100.99%	100.53%	100.42%
Med.	21.9	3.0	100.45%	99.38%	98.46%	97.20%	96.32%	96.26%
St. Dev.	0.4117	0.0073	0.0120	0.0153	0.0184	0.0213	0.0210	0.0216

7.3.3.2 CCT, CIE_x, CIE_y & Chromaticity Shift($\Delta u'v'$)

S/N	Initial(0 h)			Chromaticity Shift($\Delta u'v'$)					
	CIE _x	CIE _y	CCT	1000 h	2000 h	3000 h	4000 h	5000 h	6000 h
C01	0.43180	0.40670	3113	0.00030	0.00156	0.00294	0.00329	0.00348	0.00433
C02	0.42890	0.40220	3128	0.00010	0.00078	0.00256	0.00275	0.00333	0.00394
C03	0.43610	0.40880	3056	0.00081	0.00156	0.00350	0.00376	0.00434	0.00512
C04	0.43320	0.40450	3070	0.00010	0.00092	0.00305	0.00330	0.00388	0.00492
C05	0.43140	0.40140	3077	0.00022	0.00120	0.00275	0.00306	0.00364	0.00434
C06	0.42980	0.40200	3110	0.00022	0.00085	0.00256	0.00266	0.00324	0.00402
C07	0.43110	0.40190	3086	0.00067	0.00128	0.00308	0.00336	0.00394	0.00520
C08	0.43610	0.40820	3051	0.00067	0.00184	0.00306	0.00326	0.00383	0.00460
C09	0.43110	0.40490	3111	0.00041	0.00135	0.00288	0.00300	0.00358	0.00434
C10	0.43360	0.40520	3069	0.00045	0.00156	0.00284	0.00291	0.00348	0.00442
C11	0.43470	0.40330	3036	0.00020	0.00086	0.00244	0.00278	0.00336	0.00419
C12	0.43210	0.40520	3095	0.00030	0.00086	0.00216	0.00214	0.00272	0.00341
C13	0.42960	0.40370	3127	0.00014	0.00150	0.00278	0.00288	0.00347	0.00410
C14	0.43840	0.40850	3015	0.00036	0.00135	0.00306	0.00326	0.00384	0.00489
C15	0.43230	0.40580	3098	0.00020	0.00099	0.00216	0.00220	0.00278	0.00355
C16	0.43310	0.40510	3078	0.00020	0.00120	0.00266	0.00306	0.00364	0.00412
C17	0.43220	0.40350	3080	0.00057	0.00149	0.00361	0.00386	0.00444	0.00548
C18	0.43240	0.40490	3089	0.00014	0.00099	0.00225	0.00242	0.00300	0.00362
C19	0.43060	0.40400	3113	0.00010	0.00128	0.00261	0.00288	0.00347	0.00430
C20	0.43090	0.40440	3110	0.00030	0.00163	0.00280	0.00292	0.00350	0.00408
C21	0.42940	0.40350	3129	0.00020	0.00100	0.00222	0.00242	0.00300	0.00356
C22	0.43130	0.40550	3113	0.00022	0.00127	0.00272	0.00306	0.00364	0.00461
C23	0.43040	0.40460	3122	0.00051	0.00156	0.00272	0.00284	0.00342	0.00406
C24	0.43570	0.40650	3044	0.00072	0.00150	0.00306	0.00333	0.00391	0.00489
C25	0.43750	0.40870	3032	0.00072	0.00170	0.00319	0.00332	0.00389	0.00495
Avg.	0.43255	0.40492	3086	0.00035	0.00128	0.00279	0.00299	0.00355	0.00436
Min.	0.42890	0.40140	3015	0.00010	0.00078	0.00216	0.00214	0.00272	0.00341
Max.	0.43840	0.40880	3129	0.00081	0.00184	0.00361	0.00386	0.00444	0.00548
Med.	0.43210	0.40490	3089	0.00030	0.00128	0.00278	0.00300	0.00350	0.00433
St. Dev.	0.0026	0.0021	32.83	0.00022	0.00031	0.00038	0.00042	0.00042	0.00055

8 TEMPERATURE MEASUREMENT POINT (TMP) DEFINITION

Ta (Measured Point of Ambient Temperature)

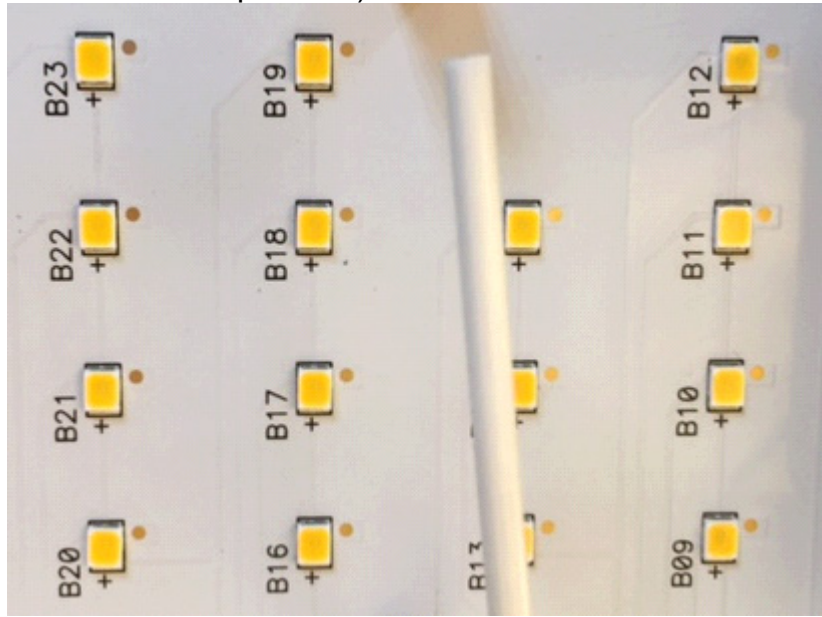

Ts (Measured Point of Case Temperature)

